



DM05 Display

Functionality Introduction

Product Name: FSTN Screen LCD Display

Product Model: DM 05



	Editor	Editor
Editor	Leo Liao	2020.11.14
Checked		
Approved		

Modification History



Version No	Reviser	Date	Revision content
V1.01	Leo Liao	2020.12.14	Initial version
V1.02	Leo Liao	2021.2.23	1. Add declaration content 2. Revise dimensions and sizes 3. Add software version interface

 Hangzhou VeloFox Intelligent Technology Co., Ltd.	文件编号	
	版本号	1.02

Declaration

DM05 functional definition is a function definition description of the standard-version DM05 display produced by Velofox , and is part of the technical documentation.

All of Velofox’s display products are customized according to the electric system’s requirements. While this document is a reference for complete function definitions, operation instructions, and error codes, any configuration difference between your display and the standard DM05 is possible, due to various technical requirements in different ebike applications. Please consult your drive system supplier for additional function requirements and data display.

If you have any questions about DM05 functional definition, please consult our sales or technical support team.

Our company (VeloFox ®) reserves all the rights to interpret and explain DM05 functional definitions.

Hangzhou Velofox Intelligent Technology Co., Ltd

A. Product Introduction		5
1. Product name and model		5
2. Product introduction		5



3. Range of application	5
4. Appearance and size	5
5. Display coding rules	6
B. Product manual	7
1. Specifications	7
2. Function overview	7
3. Installation	8
4. Interface	8
4.1 Boot interface	8
4.2 Basic interface and operation	9
4.3 Function interface introduction	9
Boot interface and basic function interface	9
Other functions indication	10
Setting interfaces	12
* Setting RTC	14
5 Button definition	14
5.1 Button name:	14
5.2 Definition of button operation:	15
6 Basic function operation	15
6.1 Turn on/off the display	15
6.2 Assist level switch	16
6.3 Information switch	16
6.4 Light control function	17
6.5 Speed info indication	17
6.6 Walk assist function	18
6.7 Battery power indicator and assist power output	18
7 Setting function	19
Reference table for the circumference value corresponding to common wheel diameters:	
.....	22
8 Data clearance	22
9 Error information	23
10 Wire definition	24
10.1 Standard wires definition:	24
10.2 Standard conversion wire specifications:	24
C. Package specifications	25
D. Note	26

 Hangzhou VeloFox Intelligent Technology Co., Ltd.	文件编号	
	版本号	1.02

A. Product Introduction

1. Product name and model

FSTN screen display of electric power assist bike

Product model: DM05

- DM05 includes two versions of UART communication and CAN BUS communication
DM05_U corresponds to UART communication version;
DM05_C corresponds to CAN BUS communication version.
- All DM05 products are available to add Bluetooth function in its hardware.

2. Product introduction

- ✧ Imported tempered glass, 4D extra hard, high transmittance
- ✧ 3.5 inch full viewing angels FSTN LCD display, positive & negative mode combination
- ✧ Adjustable mounting angles for mutiple installation options
- ✧ Seperated remote control with ergonomic design
- ✧ IP65 and up waterproof, excellent for outdoor use
- ✧ Built-in Bluetooth function, compatible with CAN-BUS and UART communication
- ✧ Service Tool function for fast firmware upgrade, parameter setting, and easy maintenance
- ✧ Optional RTC clock function
- ✧ Optional auto light on/off function

3. Range of application

Suitable for all E-bikes that comply with EN15194 standard

4. Appearance and size

The shell material of DM06 is PC+ABS, the screen is made of imported tempered glass. This



product is mid-mount on the horizontal tube with a handlebar size of ϕ 22.2mm, ϕ 25.4mm, ϕ 31.8mm. The remote control is left mounted on the horizontal tube with a handlebar size of ϕ 22.2mm, ϕ 23.8mm.

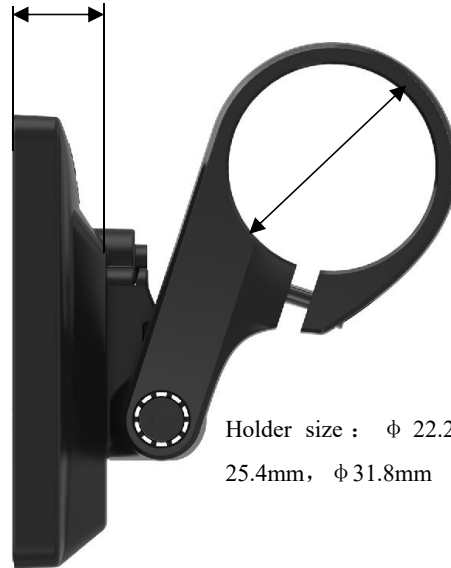

Holder size : ϕ 22.2mm , ϕ 25.4mm, ϕ 31.8mm

5. Display coding rules



DM05A-C01M020340001

A08.01-36V2570

As shown in above picture:

DM05A-C01M020340001

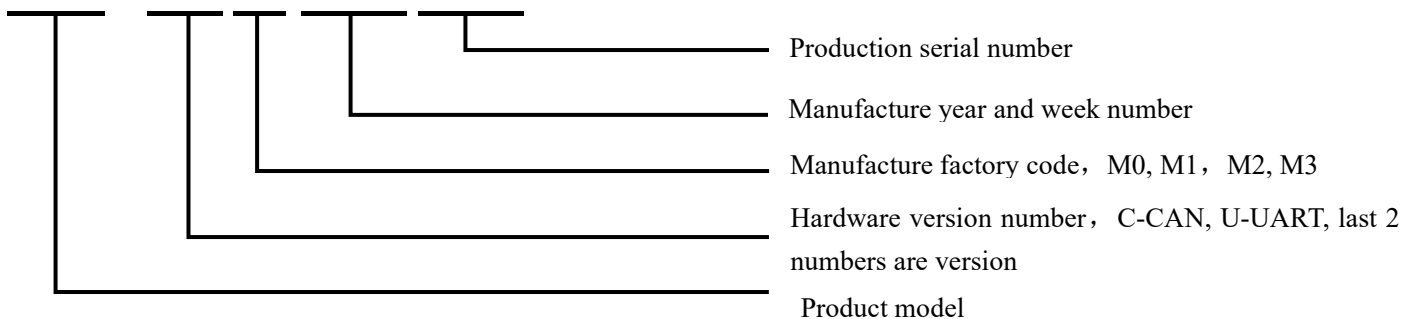

A08.01-36V2570XX

 杭州威狐智能科技有限公司 Hangzhou VeloFox Intelligent Technology Co., Ltd.	文件编号	
	版本号	1.02

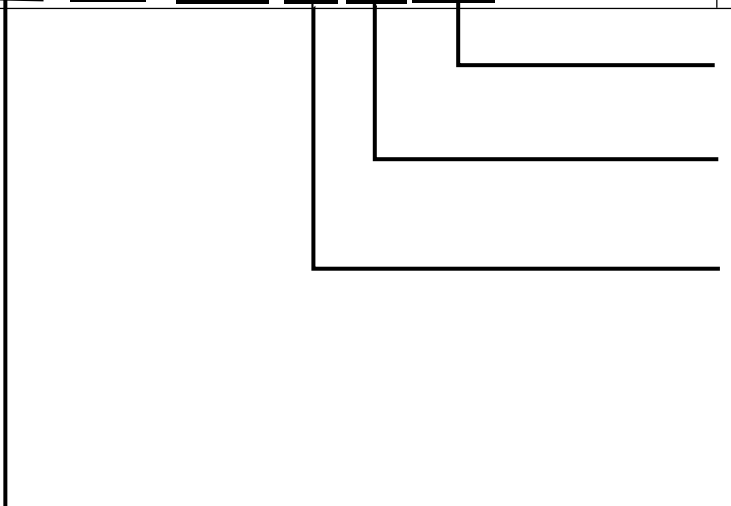
	Parameter character value (reserved)
	Parameter character value (wheel size value, 700C=70, 27.5=27)
	Parameter character value (speed limit information, range from 04 to 46)
	Parameter character value (voltage, 24/36/43/48/52, can be expanded)
	Customer software version number (may omit)
	Customer code

B. Product manual

1.Specifications

- ① Power supply: DC 24V/36V/48V
- ② Rated current: 30 mA
- ③ Shutdown leakage current: <1uA
- ④ Screen specification: 3.5 inch FSTN LCD display
- ⑤ Communication method: UART/ CAN-BUS
- ⑥ Operating temperature: -10° C ~ 60° C
- ⑦ Storage temperature: -20° C ~ 70° C
- ⑧ Waterproof level: IP65

2.Function overview

- ① Left side independent buttons with ergonomic design
- ② Unit: Km/Miles

 Hangzhou VeloFox Intelligent Technology Co., Ltd.	杭州威狐智能科技有限公司	文件编号	
		版本号	1.02

- ③ Display key riding data, speed, mileage, battery info, etc
- ④ Walk assist function
- ⑤ Optional: Auto light on/off function
- ⑥ Error code indication
- ⑦ *Optional: Real-Time Clock, for a current time indication
- ⑧ Range and battery indication (*available if BMS provides necessary info)
- ⑨ Motor power output
- ⑩ *Optional: Bluetooth function, for wireless connection for data transmission
- ⑪ *Optional: Service reminder function
- ⑫ Parameters setting and advanced setting

3. Installation

- ① Display locking clip includes two handle bar sizes, size A Φ 31.8mm, B Φ 25.4mm. Please include the requested locking clip size in the purchase order.

Installing DM05 display: Adjust display to a position easy to operate, using M3*10 hex set to screws and tighten. Tightening torque: 0.8N.m

***Note: Damage caused by excessive torque is not covered by the warranty.**

- ② Place remote button on the left side of horizontal tube, for more remote button models, please refer to Velofox product catalog.
- ③ Connect the 5 pin plug to the docking plug of the controller

4. Interface

4.1 Boot interface



Boot logo interface is displayed for 2 seconds after the display is turned on. When the

communication connection is established, display enters the main interface which shows information obtained from the controller. (All data displayed is following communication protocol provided by the customer)

4.2 Basic interface and operation



- ① All RM series buttons are compatible with DM05 series displays
- ② Standard outlet is a designated waterproof connector, which is convenient for after-sales maintenance and replacement
- ③ 3.5 inch FSTN LCD screen combines positive and negative mode display

4.3 Function interface introduction

Boot interface and basic function interface

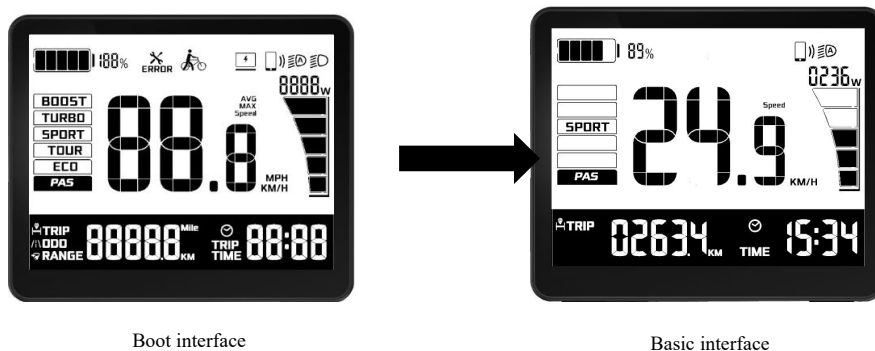

Boot logo interface is displayed for 3 seconds after display is turned on. When the



 Hangzhou VeloFox Intelligent Technology Co., Ltd.	文件编号	
	版本号	1.02

communication connection is established, display enters the main interface, showing real-time information stored in the controller and battery BMS according to the communication protocol. (Battery indicator will not show battery percentage if BMS info is not available)

*When RTC and Auto Light functions are included in chosen product, the main function interface will display real time clock and enter into auto light setting by default.

Other functions indication



TRIP info and related info indication

Subtotal mileage TRIP is displayed next to sign  with five , reserving one decimal place. After exceeding 9999.9, the decimal point is not displayed, with the maximum value of 99999. After exceeding the maximum value 99999, the displayed number is the actual TRIP data minus 100000.

When switching the subtotal mileage interface, the average speed AVG SPEED is displayed in the speed display area, with the maximum value of 99.9. Statistics of riding usage time of subtotal mileage is displayed on the bottom right, as shown in the following picture:



Odometer and related info indication

Odometer info is displayed next to sign  with 5 . If it exceeds 9999.9, the decimal point is not displayed, and the maximum value is 99999. If it exceeds the maximum value 99999, the displayed number is the actual ODO minus 100000 (If actual ODO is 100001, the displayed number is 1). To clear ODO info, service tool is required.

When switching ODO interface, the speed display area displays the maximum speed MAX SPEED, with a maximum value of 99.9

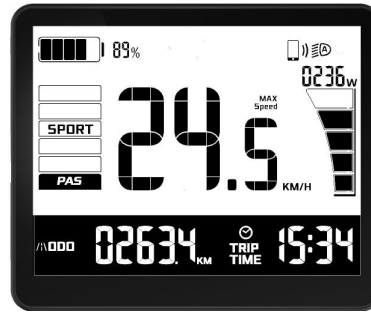

Range info indication

Range information is provided by the controller and is displayed next to **RANGE** with five **0**, reserving one decimal place, with a maximum value of 999.9



*RTC

If chosen display model includes RTC module in its hardware, display will show real time clock on the bottom right corner



Error code indication

When the display receives the error info returned by controller, it will show **ERROR** on basic interface, and a numerical error code will be displayed in speed display area, blinking at 1Hz. While error code is displayed, PAS level and motor output will be shown empty, and the rest of the display functions are normal. The motor will respond to error info.

 杭州威狐智能科技有限公司 Hangzhou VeloFox Intelligent Technology Co., Ltd.	文件编号	
	版本号	1.02

Error code interface is shown as below:







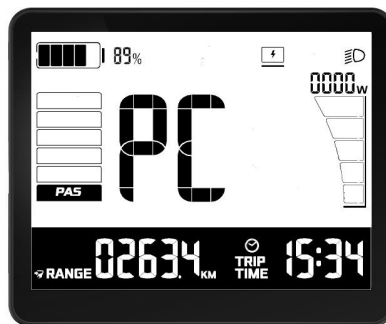

PC Connection and Service Tool

Connect display to PC using service tool provided by Velofox, then the corresponding firmware upgrade and system configuration modification can be carried out on PC. When display is connected to PC correctly, the display's interface will show icon , and the speed display area will become characters PC. In the meantime, PAS level and motor output will be shown empty, and the rest of the display functions are normal. The display interface is shown as below:



Setting interfaces

Within 10s after turning on display, long press M button to enter setting interface, short press 、 to switch between setting interfaces. In any setting interfaces, short press M to enter parameter editing state, the selected parameter will blink at 1 Hz, short press 、 to modify specific value. Long press M button to confirm and exit editing state, and long press M button again to return to previous page.

Short press  button to enter into each setting item accordingly; Short press  button to previous setting item. Setting interface is shown as below:

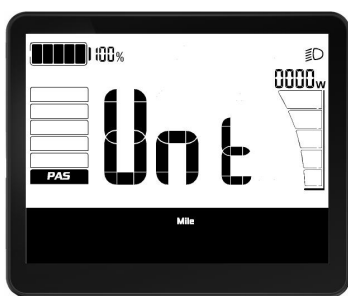

Unit setting interface

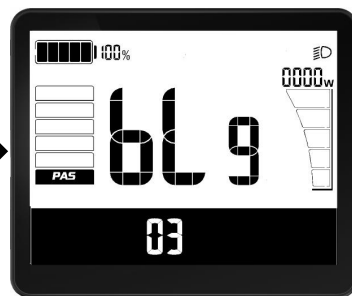

Backlight setting interface

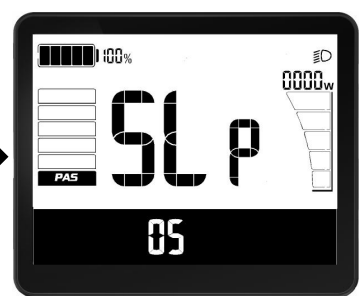

Sleep time setting

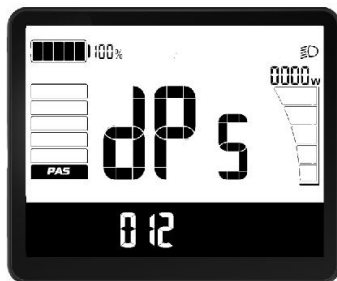

Software version interface

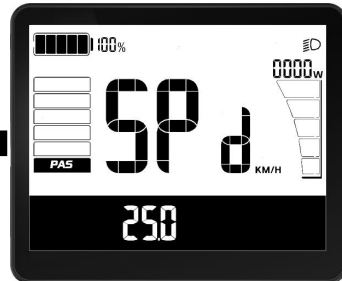

Speed limit

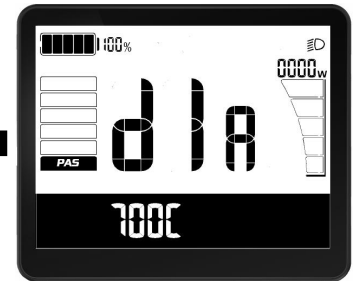

Wheel size setting

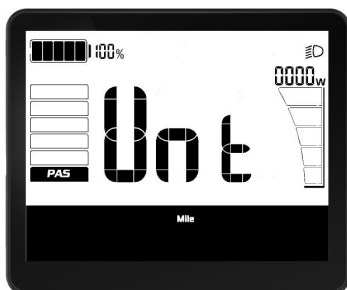

Unit setting interface

For more setting operation illustration, please refer to part 7

*Setting RTC

If chosen display model includes RTC module in its hardware, the display supports setting and calibration of real-time time. RTC time setting interface is after the sleep time setting interface, and it follows the standard setting operation.

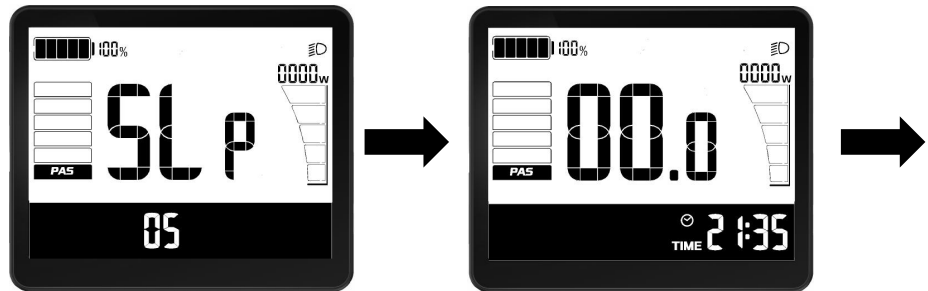

Sleep time setting interface

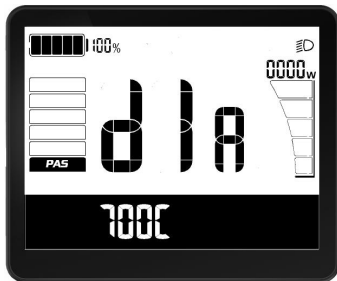

RTC setting interface

Wheel diameter setting interface

5 Button definition

5.1 Button name:



Power button: Turn on/off the display

Adjust button: Adjust the assisting power level during riding and switch functions

Long press the adjust buttons to perform specific function operation

Function button: Switch interface functions and enter into parameter setting interface

5.2 Definition of button operation:

Operation Type	Description
Short press	Press the button and soon released, while the button is released, the function activated accordingly
Long press	Press the button and hold, when the hold time exceeds the setting time (generally 2 seconds), the function is activated accordingly.

6 Basic function operation



6.1 Turn on/off the display

When display is properly connected with controller, turn on the display by long press 

button until boot logo interface appears and shortly enters the basic interface. Turn off the display by

long press  button until display is turned off. If the rider does not perform any operation on the display within set sleep time, while speed is 0, and current is less than 1A, then the display will be turned off automatically. Set sleep time is self-defined by user in setting interface.

6.2 Assist level switch

Short press  ,  buttons to switch PAS level. There are five PAS levels ECO/TOUR/SPORT/TURBO/BOOS, When PAS level is empty, it means no pedal assist power output, that is PAS off state.

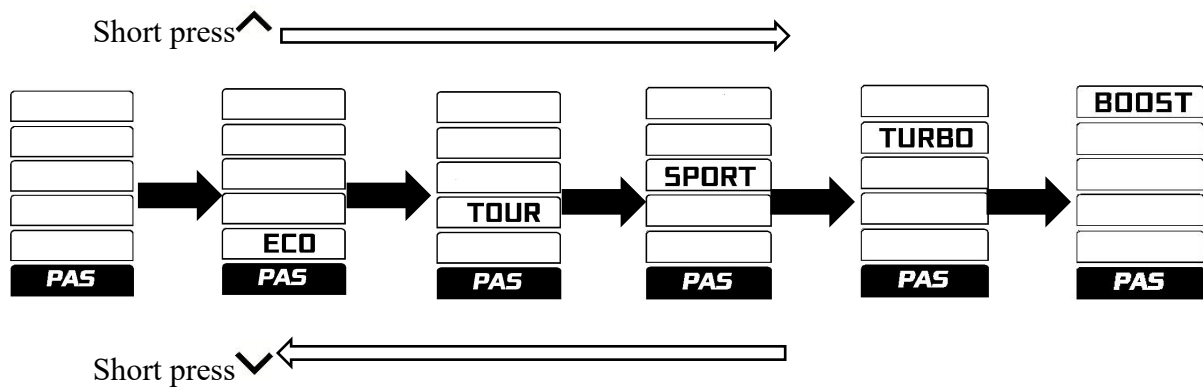

6.3 Information switch

In a power-on state, short press M button to switch in cycles among TRIP, ODO and RANGE: TRIP/AVG -> ODO/MAX -> RANGE/AVG. In a normal riding state, if the bike speed is greater than 0, and the display is not in the basic interface, then basic interface will be automatically returned to after 5 s no operation on the M button.





***If BMS communication is not available in the system, display can not obtain RANGE info, therefore RANGE can not be shown.**

Switching of TRIP, ODO and RANGE interfaces as follows :



6.4 Light control function

Automatic lights-on/off function is an optional function to be selected for your display. When equipped with auto light control function, display automatically detects the ambient light intensity and controls the turning on/off of the lights. The icon  on the top right corner of the basic interface indicates automatic lights-on state.



To change light state manually under auto light function, long press . That is, if the light is on under auto light function, switch off light by manually long press . If the light is off under auto light function, switch on light by manually long press , icon  on the top right corner will appear. Long press  to switch off light again. The auto light function is disabled, once the light on/off is operated manually. Shutdown and turn on the display again, to activate the auto light function.



6.5 Speed info indication

The display provides speed info indication. Under standard condition, the basic interface displays real-time speed, and switchable indication of average speed AVG and maximum speed MAX. For details, refer to 6.3 Information switch.

6.6 Walk assist function

When speed is below 6 km/h, long press and hold  button to enter walk assist mode. Motor outputs power according to the set speed and controls the actual walk speed, display shows the walk assist icon  and the real-time speed while PAS level shows empty. Release  button or any other button to exit walk assist mode, the motor is turned off, and the display gets back to the basic interface. Walk assist interface, shown as below:

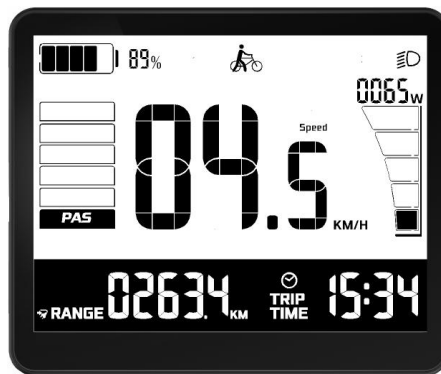

6.7 Battery power indicator and assist power output







Battery power information is divided into battery bar indication and remaining percentage indication. When battery power is normal, battery capacity is divided into 5 bars.

After battery capacity is lower than 5% or the voltage is lower than low voltage value, display will enter the low-voltage mode. In this mode battery level showed level 0 and border blink at 1Hz, with no power output from the motor, and disabled PAS level switch. Power assist level is displayed as OFF or 0. To get out of low-voltage mode, reset, and increase the voltage above low-voltage value and battery capacity above 5%.

Percentage of battery power and power level table

(Battery % info is required from BMS or controller):

SOC	Battery level	Description
$80\% \leq \text{SOC}$		Full battery level 5

 杭州威狐智能科技有限公司 Hangzhou VeloFox Intelligent Technology Co., Ltd.	文件编号	
	版本号	1.02
60% ≤ SOC < 80%		Level 4
40% ≤ SOC < 60%		Level 3
20% ≤ SOC < 40%		Level 2
10% ≤ SOC < 20%		Level 1
5% ≤ SOC < 10%		Level 0
0% ≤ SOC < 5%		Level 0 and icon blink at 1Hz

● Remarks about battery indicator:

When there is a battery communication error:

1. Display will estimate the power according to the voltage and show the battery level accordingly;
2. No battery percentage information will be shown;
3. Range information will not be displayed;
4. If the voltage is lower than the low-voltage value, the effect of the current on voltage needs to be considered when converting to a voltage at 0 current

Before communication is established, the battery percentage is not displayed, and the power bar is full and blinks at 2Hz. After battery info is acquired, power bar will stop blinking, and displays the power percentage. If communication is not successful within 5s, it will stop blinking and no power percentage will be displayed.

7 Setting function

Display provides specific parameter setting functions. The optional items of setting function will be deleted according to different market and product requirements. The following is the complete description of parameter setting and information indication function under the default state of display. Please contact our sales and technical support team for confirmation in case of any discrepancies.



Within 10s after turning on display, long press M button to enter setting interface, short press

^、v button to switch between setting interfaces. In any setting interfaces, short press M button to enter parameter editing state, the blue mark indicates chosen parameter, and selected option or value will be indicated by a white font with a grey background. Short press ^、v button to edit parameters. Long press M button to confirm parameter selection. Long press M button again to exit and return to previous page.

In any setting interfaces, short press M button to enter the next level menu, and long press M button to return to the previous level menu.

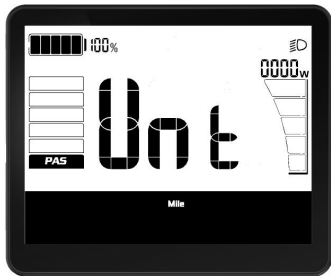
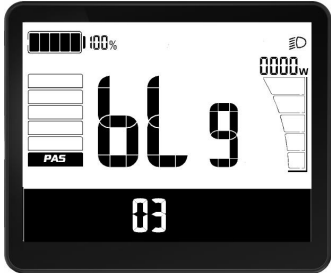
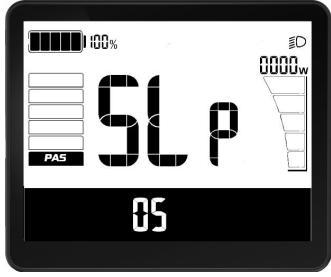

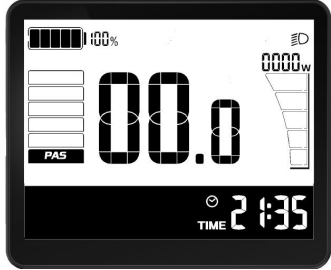
First level parameter setting interface, and the description of each parameter interface is as follow:

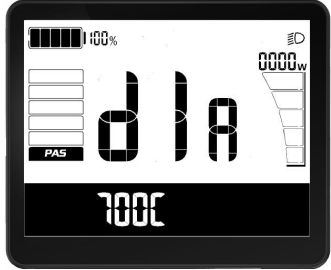
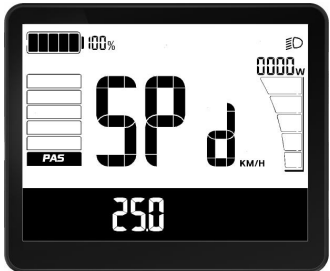
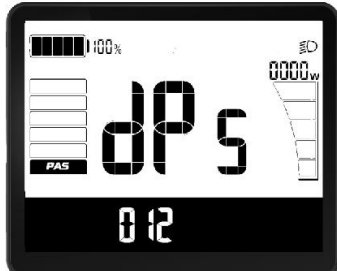
Setting items	Interface	Description	Setting data	Remark
Unit setting		UNT=Unit	Value=KM/H MPH	Default Value=KM/H KM/H—Metric MPH—Imperial
Backlight level setting		bLG=Back light	Value= LEVEL1, backlight level 60% Value= LEVEL 2 backlight level 80% Value= LEVEL 3 backlight level 100%	Default Value= LEVEL 1
Auto shutdown time		SLP= Auto sleep	Value=0-30 min	Default Value=5min OFF means no auto shutdown

 杭州威狐智能科技有限公司 Hangzhou VeloFox Intelligent Technology Co., Ltd.		文件编号		
		版本号	1.02	
Real time clock		N/A	N/A	 Hour: minutes
Wheel size setting		dIA=Wheel diameter	Value=12, 14, 16, 20, 24, 26, 27, 27.5, 700C, 28, *29, *CCF (* default unit is inch)	Default value: 26 When value=CCF, customization is allowed
Speed limitation setting		SPd=Speed limitation	Value=5-46, increment is 1, unit is km/h .	Default value: 25
Software version info		DPS= Display software version	Read only	Default value

* Note: The wheel diameter option CCF is the wheel diameter perimeter setting, which needs to be supported by the controller communication protocol.

When the CCF value is selected for the wheel diameter parameter, user is allowed to customize the wheel diameter circumference value (four-digit length value in mm).

Long press M for selecting CCF, when speed display area shows blinking CCF icon and function display area shows  with thousandth digit blinking at 2 Hz . Short press   to select value and short press M to switch to next digit selection. Long press M to confirm input of each digit, and long press M button again to exit the current setting and return to previous menu. The type of wheel diameter configuration will be recorded to the controller. If customer chooses wheel diameter CCF option, then CCF page will be displayed directly when entering the wheel diameter

setting.

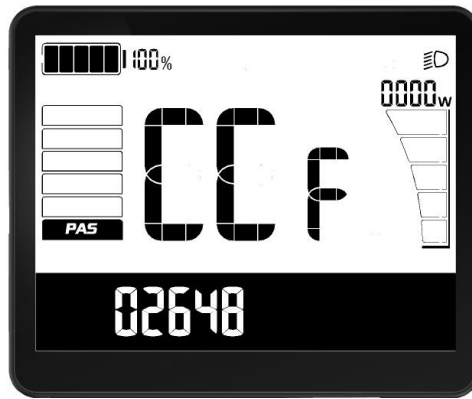

Reference table for the circumference value corresponding to common wheel diameters:

C ETRTO 16 x 1.75 x 2		kph mph	ETRTO 16 x 1.75 x 2		kph mph
47-305	16x1.75x2	1272	32-630	27x1 1/4	2199
47-406	20x1.75x2	1590	28-630	27x1 1/4 Fifty	2174
37-540	24x1 3/8 A	1948	40-622	28x1.5	2224
47-507	24x1.75x2	1907	47-622	28x1.75	2268
23-571	26x1	1973	40-635	28x1 1/2	2265
40-559	26x1.5	2026	37-622	28x1 3/8x1 5/8	2205
44-559	26x1.6	2051	18-622	700x18C	2102
47-559	26x1.75x2	2070	20-622	700x20C	2114
50-559	26x1.9	2089	23-622	700x23C	2133
54-559	26x2.00	2114	25-622	700x25C	2146
57-559	26x2.125	2133	28-622	700x28C	2149
37-590	26x1 3/8	2105	32-622	700x32C	2174
37-584	26x1 3/8x1 1/2	2086	37-622	700x35C	2205
20-571	26x3/4	1954	40-622	700x40C	2224
	14x1.75	1046		12x1.75	957

8 Data clearance

Within 10s after display is turned on, when display is at TRIP interface, long press M button to show TRIP data clearance window, while TRIP icon is blinking at 1 Hz, short press M button to confirm data clearance. To exit data clearance window, long press M button or remain no operation for 30s.

After clearance, the subtotal mileage TRIP is 0, average speed, and max speed is 0. ODO information can't be cleaned manually on the display, professional service tools are required.

9 Error information

Display can warn bike faults. When faults are detected, error code will be shown on the interface and blink at 1Hz. When error code is shown, ODO, TRIP and RANGE icon will not be shown, while the rest of the display functions remains normal. Press M button for a 5s display of ODO, TRIP, and RANGE info. After 5s, the display will return to the error code interface.

Error code interface as shown below:

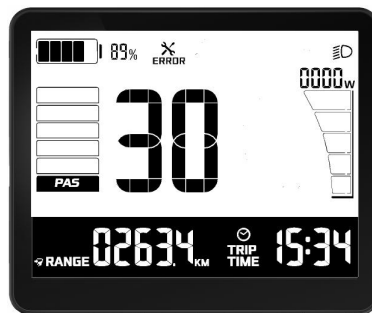

Bafang protocol's error code information table:

(Please note different protocol has different error code system. If an error code appears, please communicate with our sales and technical support team to verify and confirm!):

Error code	Error description	Suggest operation
"04" shown at speed	throttle doesn't turn back to zero position (stay on the high position)	Check if the throttle turned back
"05" shown at speed	throttle failure	Check throttle
"07" shown at speed	overvoltage protection	Check battery voltage
"08" shown at speed	failure of motor's hall signal wire	Check motor
"09" shown at speed	failure of motor's phase wire	Check motor
"11" shown at speed	failure of the motor's temperature sensor	Check controller
"12" shown at speed	failure of the current sensor	Check controller
"13" shown at speed	failure of the temperature of the battery	Check battery
"14" shown at speed	Controller temperature is too high, and reaches the protection point	Check motor
"21" shown at speed	failure of the speed sensor	Check the install position of the speed sensor

 Hangzhou VeloFox Intelligent Technology Co., Ltd.	杭州威狐智能科技有限公司	文件编号	
		版本号	1.02
"22" shown at speed	Failure of BMS communication	Change battery	
"30" shown at speed	communication failure	Check connector to controller	

10 Wire definition

10.1 Standard wires definition:

The standard outlet of the display DM05 is in the form of a designated waterproof connector. The standard outlet needs to match the corresponding conversion wire. Velofox has set a corresponding standard for conversion wire length and interface standards. If the standard setting cannot be met, specially customized conversion wires are required.

*All displays products are open to harness and connector customization.

Standard outlet in a sample is shown in the figure below:

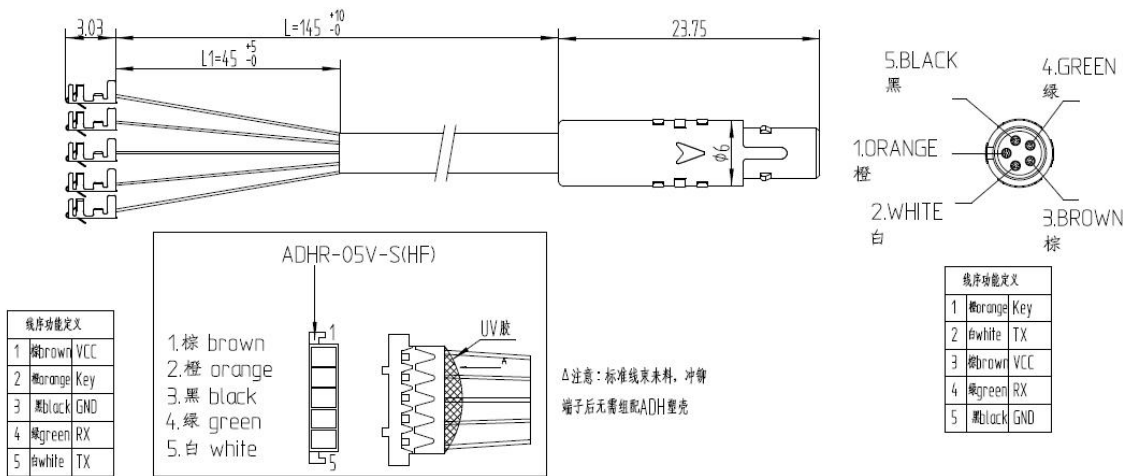
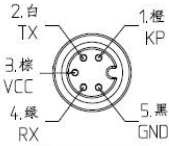

Table 1 Standard wire definition

No.	Color	Function
1	Orange(KP)	Power lock control wire
2	White(TX)	Data transmission wire of display
3	Brown(VCC)	Power wire of display
4	Green(RX)	Data receiving wire of display
5	Black(GND)	GND of display
6	reserve	reserve

10.2 Standard conversion wire specifications:

Adaptor-C2H:



线序功能定义	
1	#orange Key
2	#white TX
3	#brown VCC
4	#green RX
5	#black GND

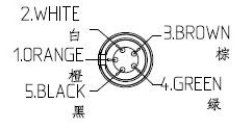
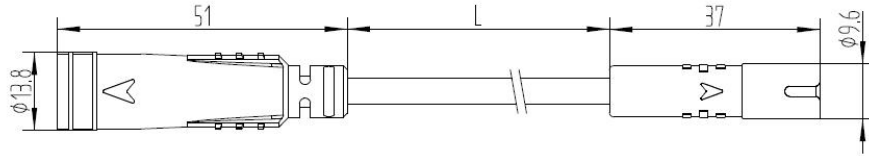

线序功能定义	
1	#orange Key
2	#white TX
3	#brown VCC
4	#green RX
5	#black GND

线长L允许根据客户订单调整，优先选用推荐线长尺寸，推荐规格如下：

L<mm>	50	100	150	350	550	650	850
-------	----	-----	-----	-----	-----	-----	-----

Adaptor-C2J:

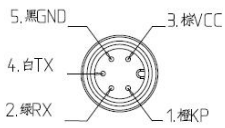

线序功能定义	
1	#orange Key
2	#green RX
3	#brown VCC
4	#white TX
5	#black GND

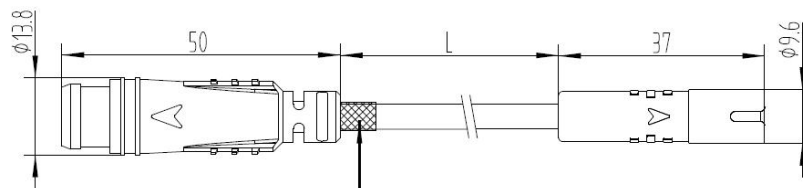

410mm白色热缩套管标记
Adaptor C2J

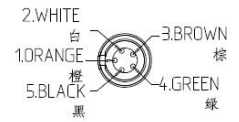

线序功能定义	
1	#orange Key
2	#white TX
3	#brown VCC
4	#green RX
5	#black GND

线长L允许根据客户订单调整，优先选用推荐线长尺寸，推荐规格如下：

L<mm>	50	100	150	350	550	650	850
-------	----	-----	-----	-----	-----	-----	-----

C. Package specifications

Standard delivery, in a double corrugated box packaging. The inner layer is a double corrugated septum plus EPE foam product bag.

Outer box size: 580*390*168mm (L*W*H)

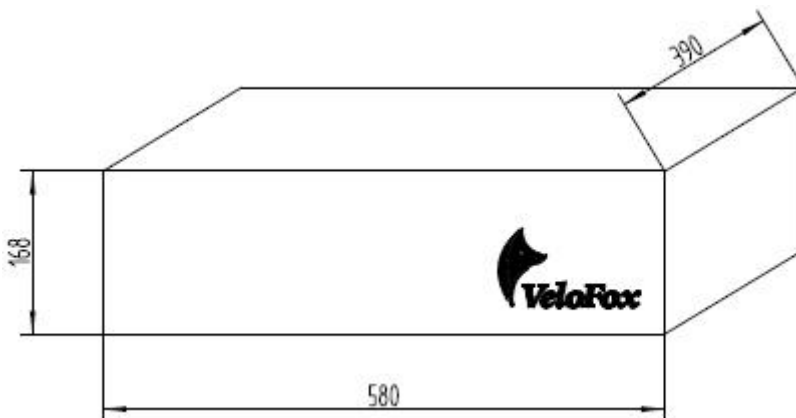

 Hangzhou VeloFox Intelligent Technology Co., Ltd.	文件编号	
	版本号	1.02

D. Note

- ✧ In the use of the display, pay attention to the security, do not plug the display in and out when the power is on;
- ✧ Try to avoid exposure in harsh environments like heavy rain, heavy snow, and strong sunlight
- ✧ When the display can't be used normally, it should be sent to repair as soon as possible